

A

H

C

PANELPRO
SERIES

MULTIPLE
SOLUTIONS
FOR
EVOLVING
WORKSPACES



H0 Plot No.33, Ecotech-12, West Greater Noida-201310
0120-6251848, +91 99990 06933
afc@afcindia.in, customercare@afcindia.in

www.afcindia.in

AFC

FURNITURE SOLUTIONS

DIVERSE SOLUTIONS FOR DIVERSE SPACES

PanelPro workstations offer a comprehensive range with aesthetic designs and color options, which seamlessly integrate with open office settings. With panel thickness of 30mm ,50mm ,60mm and multiple height and width options these workstations create contemporary bright office spaces.





HIGHLY CUSTOMISABLE

Multiple choices in colors, textures, materials and accessories to suit any office environment, these panel systems offer flexibility to reconfigure and adjust with style.

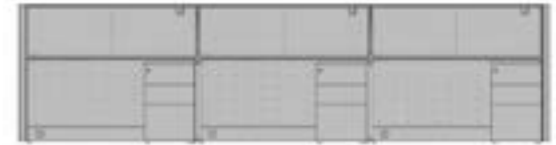

Return glass partition



Middle divider panel

SMART SOLUTIONS FOR AN INTERACTIVE ENVIRONMENT

Designed for efficient spaces which offer productive focus as well as flexibility for effective communication. PanelPro30 & Pro50 are ideal for today's modern work environment where shared productivity is essential.



Laminate pedestal with fabric cushion



30mm middle partition panel



POWERING YOUR WORKPLACE

Delivers exceptional value and creates an efficient environment for high-performance team-oriented spaces. Multitude of different panel options like glass marker board to fabric textures and colours allow flexibility while combining it with contemporary aesthetics.

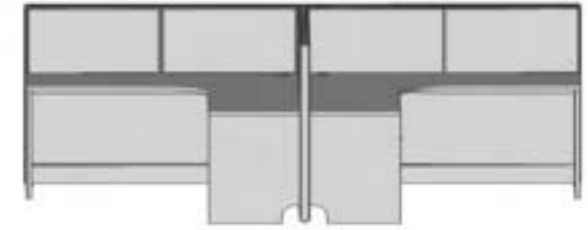

Metal pedestal with cube handles

FUNCTIONAL & LIGHT WEIGHT

PanelPro systems are great space savers and are made with light weight, rust proof aluminium frames which make them easy to transport. Functionality and aesthetic ergonomic designs combinations offer you convenient and efficient solutions.



Sleek thick return screens



Slant leg

AESTHETIC FUNCTIONALITY

Designed for open environment with clever details and thoughtful integrations, PanelPro strikes a balance between privacy and flexible team spaces. With an impressive range of configurations-Plus, Carrel, 120degree, Cubicle Clusters and more these systems fit in any space and have the flexibility to adapt and evolve.



3 layer partition
(Raceway, Fabric Screen, Clear Glass)

DYNAMIC WORKSPACES

Dynamic, flexible workstations that support teamwork and open communication. These optimize the office space and create a happy and vibrant environment

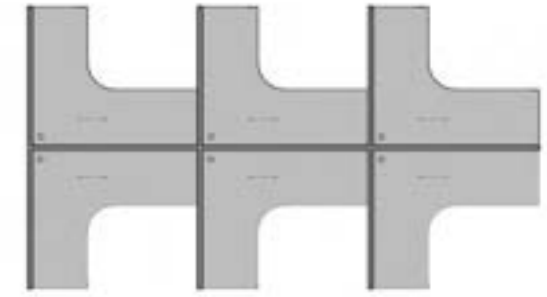

Slant Leg



PROGRESSIVE WORKHUB

Panelpro offers you a variety of choices that allow you to create office interiors that reflect your taste and style, making your space truly special.



Cubicle workstation with free standing storages, accessory rail and glass tiles giving an open look



120 degree cluster with oblique leg and combination of marker and fabric panels



"T" type cluster, with elevated frame and straight leg

- Panels of different sizes - variety of widths and heights to suit individual preferences.
- Options for various legs (straight leg / oblique leg / intermediate round pole leg and gable ends) for minimalist and light look.
- Choice of finishes and colours for laminates and metal components.
- Separators with choice of pre-lam / fabric / glass.
- Optimum wire management through 60 mm frame. Approximately 70 nos. of CAT6 cables can be accommodated.
- Easy to handle and simple wire management with data and power access both above and below work surface.
- Factory fitted panels for quick and easy installation.
- Tiles in MDF Fabric / Metal Fabric / Metal Powder Coated / Glass (frosted/toughened/ Metal Embossed / Perforated Glass (Clear/ Toughened) / Prelam / Pinup Fabric.
- Variety of accessories such as Paper trays, pen holders, bottle holders, magazine racks, bag holders, name plates, glass arr laminate marker boards.
- Choice of over 40 colours for fabric tiles.



Linear workstation with intermediate glass separators and top supporting storages with individual locks. Staggered height return partition at the aisle side

WIRED TO PERFORM

These systems feature comprehensive support of power and data routing and access for individual workstations making technology easily accessible. These systems have more than 40mm-42mm of clear space running throughout the frame / panel thus offering spacious cable ducts for ample wire space. A series of electrical raceways let you mount switches and sockets both above and below the worktop for easy access.

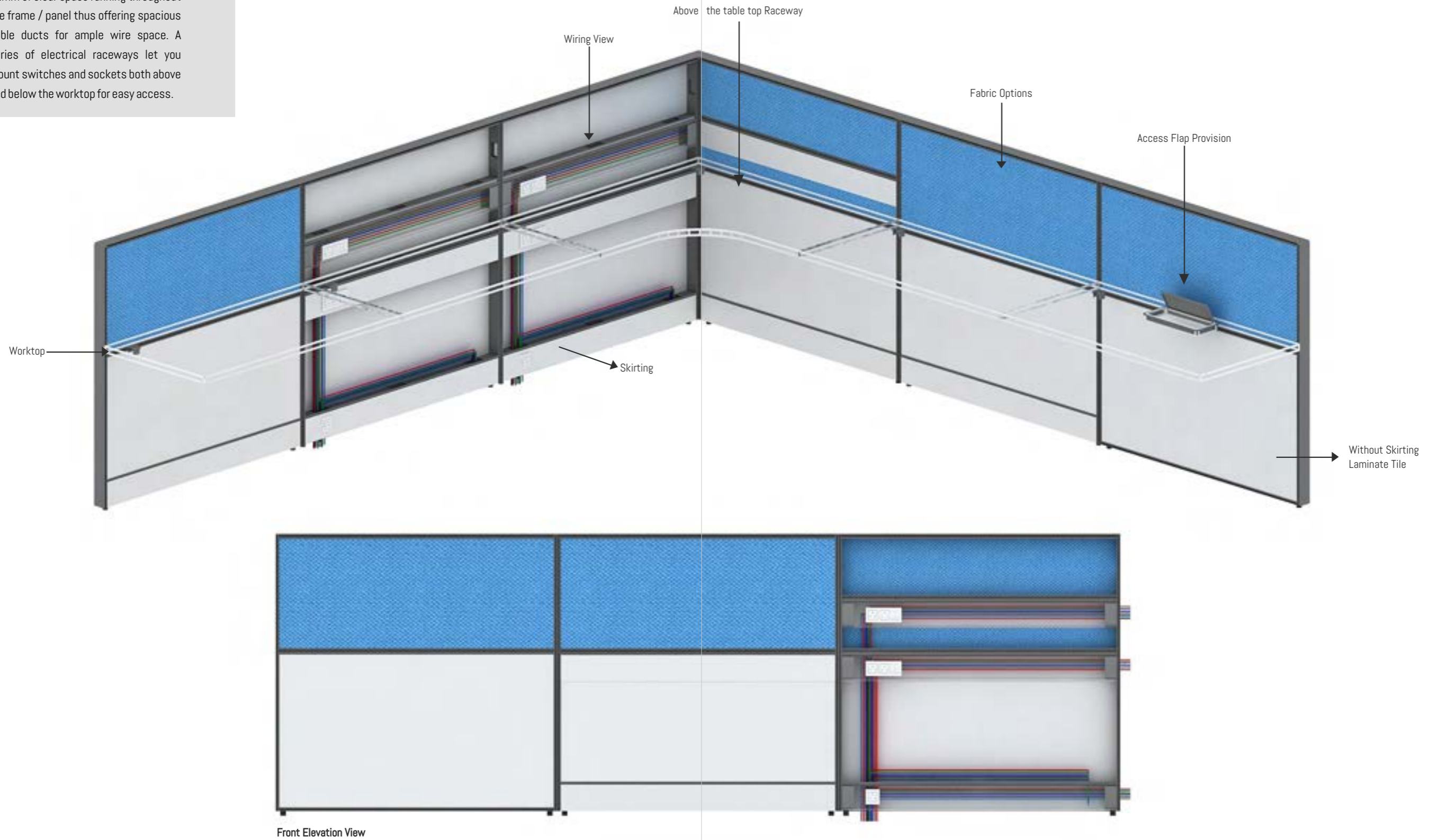

PanelPro Configuration examples

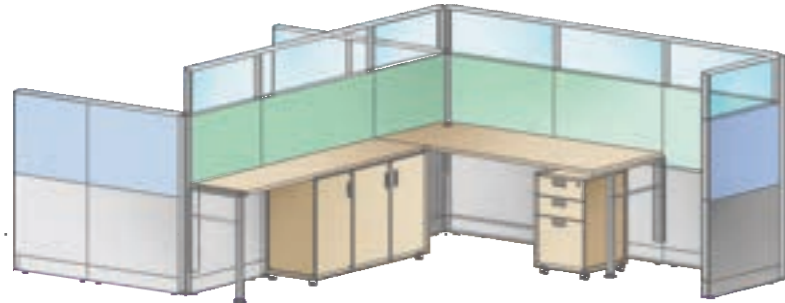

PanelPro Cabin with side credenza

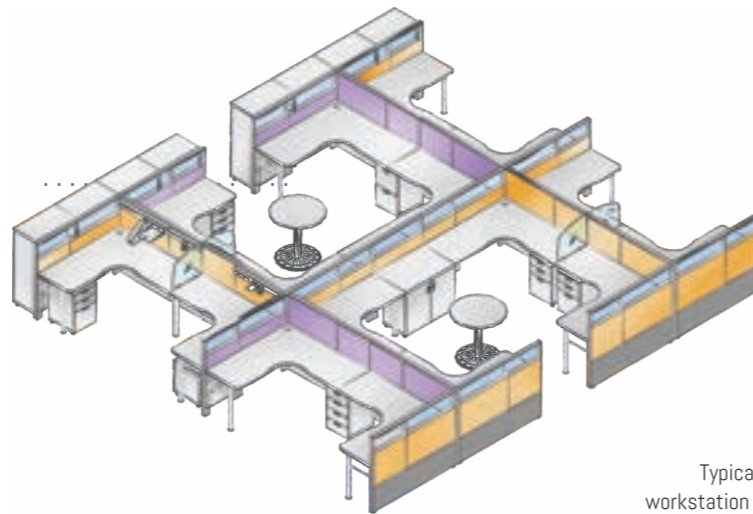

Typical PanelPro workstation cluster with asile side storages

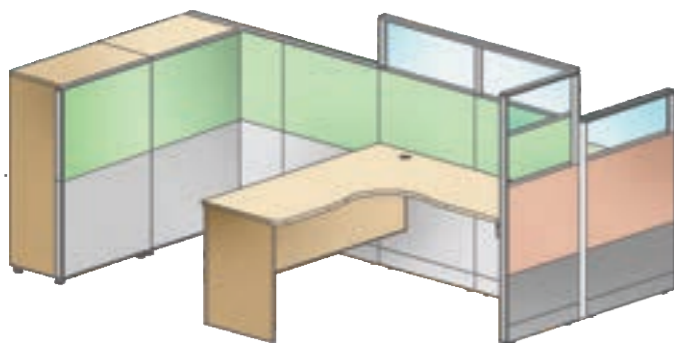

PanelPro Cubicle with staggered height partition and back storage

Your space is your playground
explore & ideate

PanelPro offer modules and combinations of frames, legs, work surfaces, storage, screens, and accessories.

PanelPro gives you the freedom to explore, ideate and extend the basic configurations into innumerable extended configurations to suit your office space requirements.

PanelPro Matches your imagination. Fits every space.

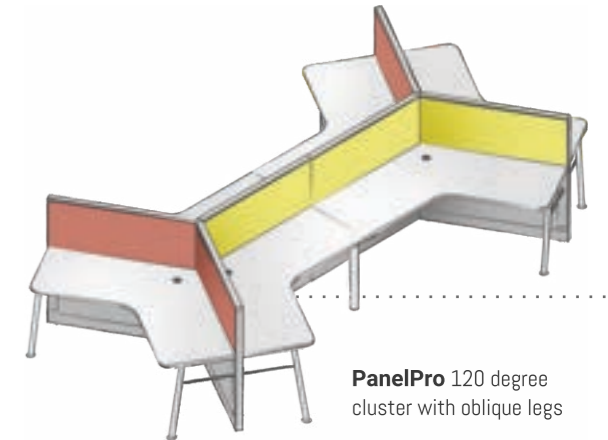

PanelPro 120 degree cluster with oblique legs

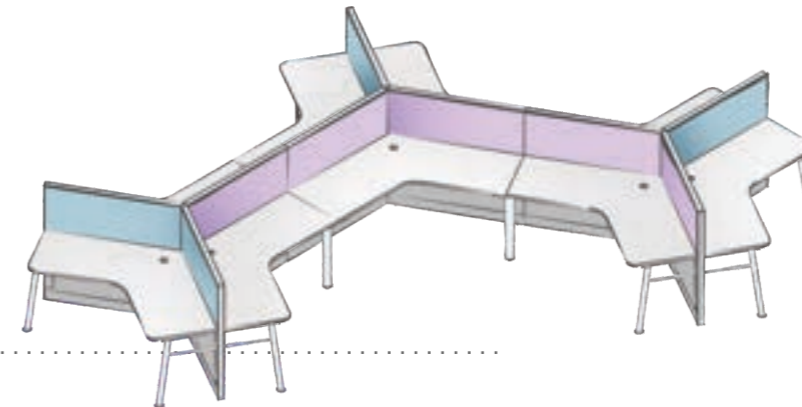

PanelPro 120 degree extended cluster with oblique legs

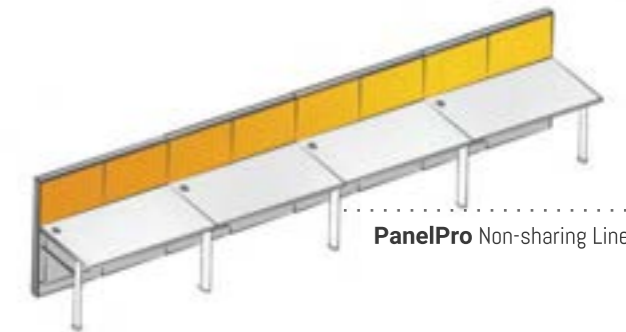

PanelPro Non-sharing Linear

Frame Height Elevations

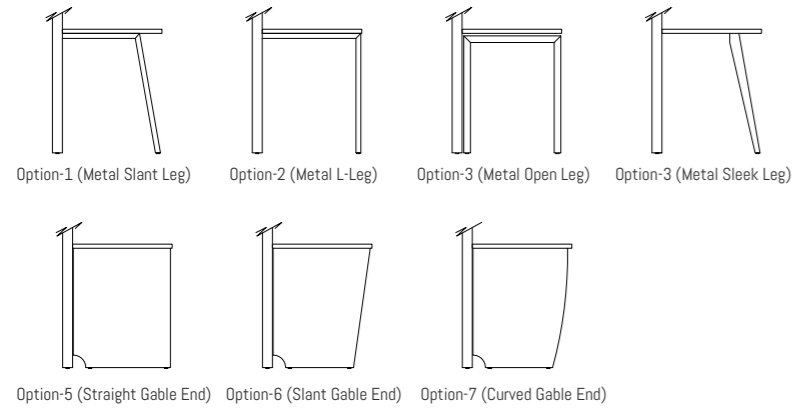
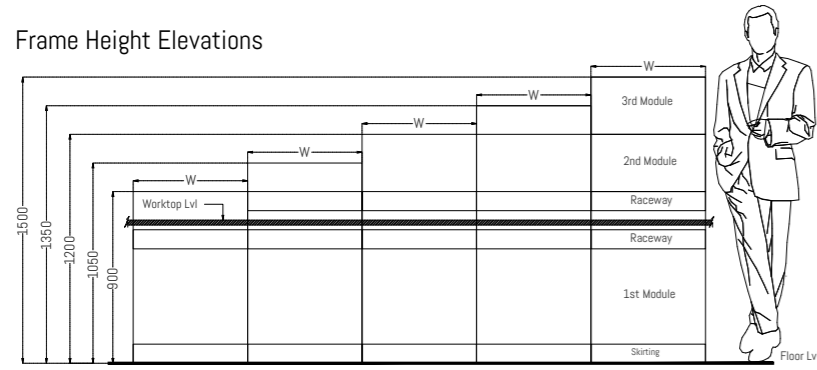

Workstation Type-1

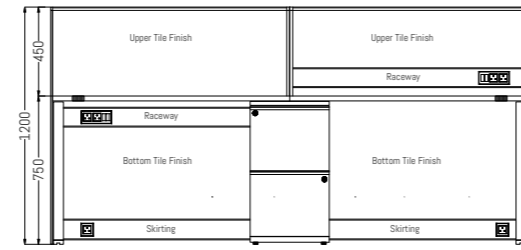

Workstation Type-2

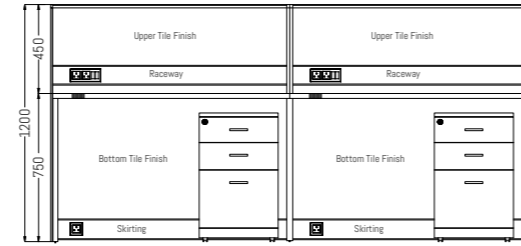

Finishes Availability

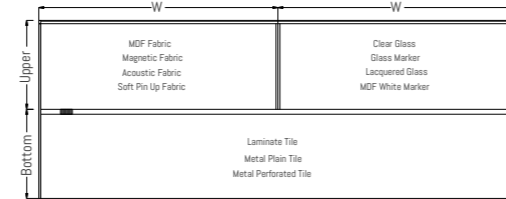

Pedestals

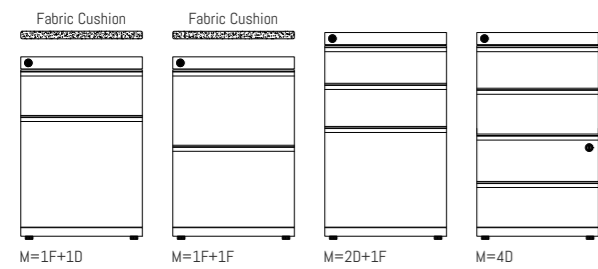

Metal Pedestals With Cube Handles

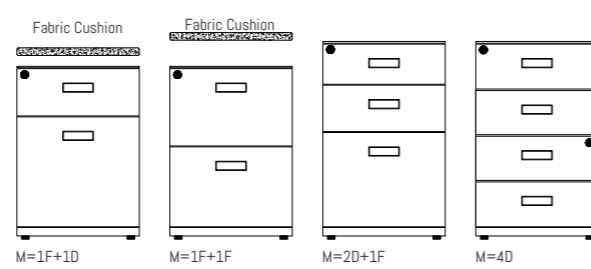

Metal Pedestals With Recessed Handles

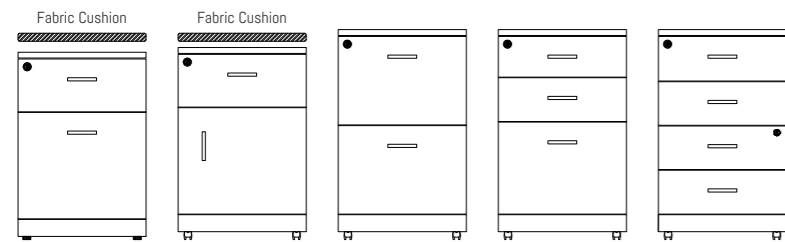

Laminated Pedestals With "I" Handles

Handles & Lock Options



Low Height Storages

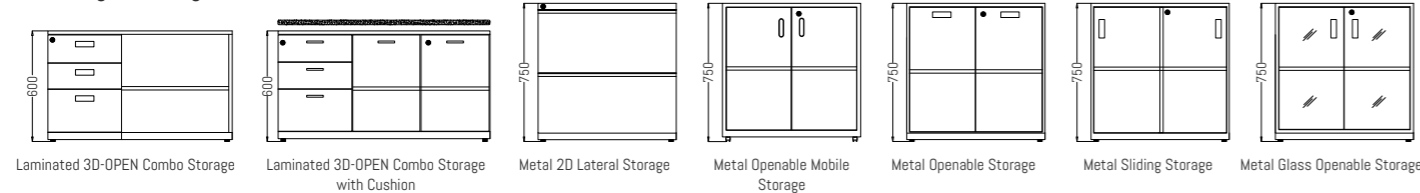

Linear Single Piece Table Top Profiles

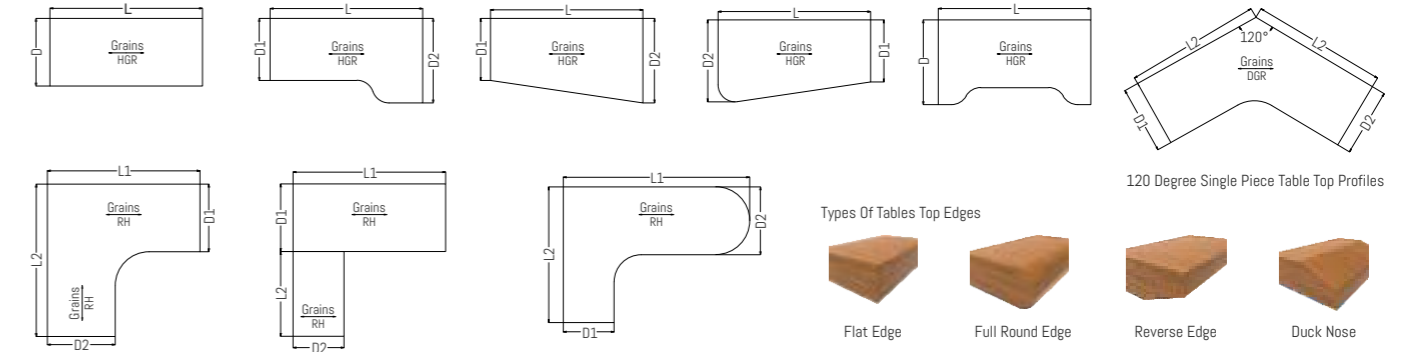

Meeting Room Table Top Profiles

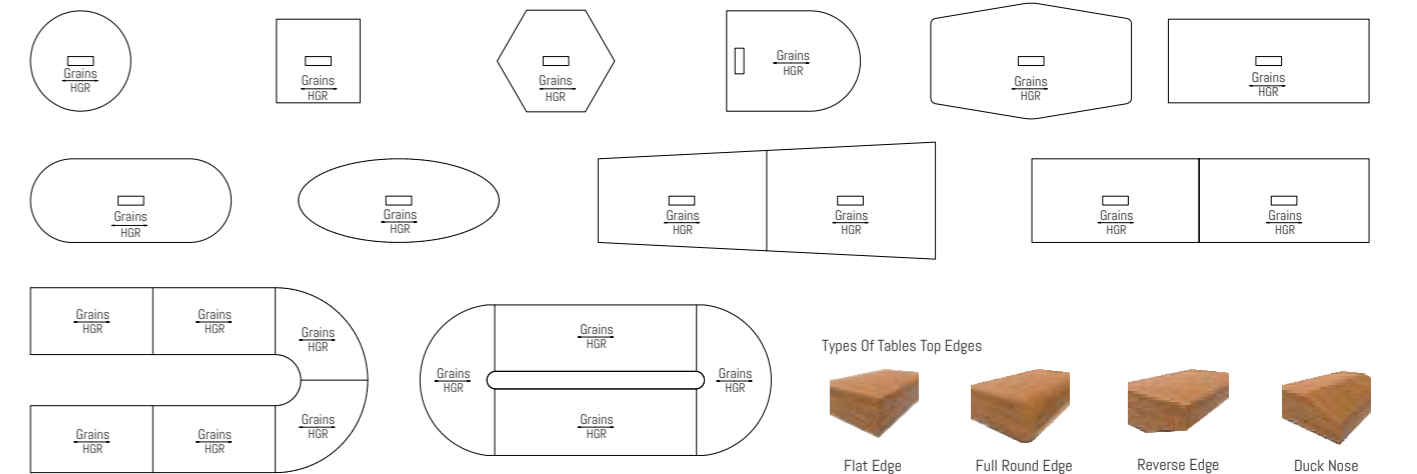

Accessories

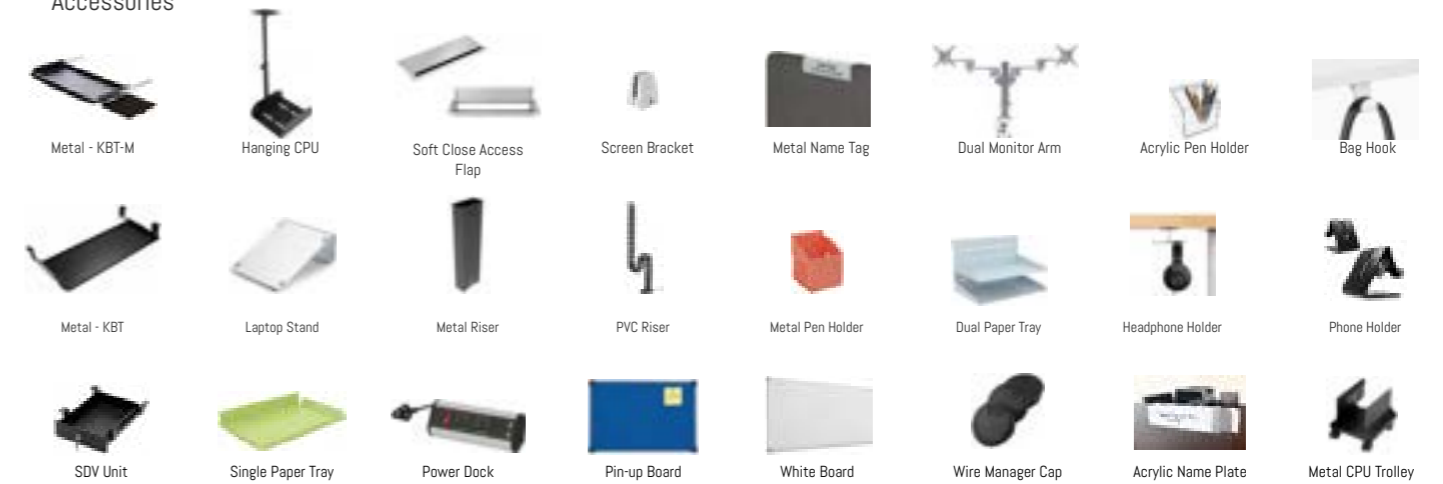

Laminated Storages w=600-750-900



CHOICE OF SURFACES & MATERIALS











Laminate

					
AFC 01 FROSTY WHITE 1103- SD	AFC 06 SILVER GREY 1104- SD	AFC 05 SLATE GREY 1105- SD	AFC 08 GOTHIC GREY 1113- SD	AFC 11 THANSAU MAPLE 3020- SD	AFC 08 GOTHIC GREY 1113- SD
					
AFC 09 MANGFALL BEECH 3018- SD	AFC 10 HIGHLAND PINE 3003- SD	AFC 13 MOLDAU ACACIA (light) 3025- SD	AFC 20 ELEGANT TEAK 3041- SD	AFC 14 MOLDAU ACACIA (dark) 3026- SD	AFC 17 CLASSIC PLANKED WALNUT 3009- SD

Glasses..... Sandwich/Lacquered

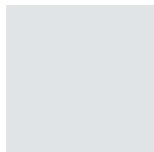
					
GL- 01 SW DEEP ORANGE	GL- 02 SW SKY BLUE	GL- 03 AQUAMARINE	GL- 04 SW LIME GREEN	GL- 05 SW LIGHT ORANGE	GL- 06 STONE GREY
					
GL- 07 CARIO	GL- 08 TRAFFIC RED	GL- 09 WHITE			

Powder Coating

					
AFC WHITE	AFC BLACK	MUNSHELL GREY	GRAPHITE GREY	SILVER GREY	DA GREY
					
MISTY GREY	LIGHT ORANGE	SEA GREEN	SKY BLUE	NUT BROWN	

Fabric

					
BABY BLUE MS-401 AFC CODE-F37	DOLPHINE MS-402 AFC CODE-F38	ELECTRIC MS-403 AFC CODE-F39	AMALFI MS-404 AFC CODE-F40	MED BLUE MS-405 AFC CODE-F41	VESURIUS MS-410 AFC CODE-F42
					
LEMON MS-427 AFC CODE-F43	DAGO ORANGE MS-426 AFC CODE-F44	WARM GLOW MS-423 AFC CODE-F45	VILLA DE SOLE MS-424 AFC CODE-F46	CINNAMON MS-442 AFC CODE-F47	SALMON MS-445 AFC CODE-F48
					
LEMON MS-420 AFC CODE-F49	CORN FLOWER MS-406 AFC CODE-F50	LILAC MS-412 AFC CODE-F51	LAVENDER MS-416 AFC CODE-F52	FLAME MS-418 AFC CODE-F53	PINK MS-415 AFC CODE-F54
					
FERNFIA MS-428 AFC CODE-F55	ROMAN GREEN MS-440 AFC CODE-F56	AZARON MS-441 AFC CODE-F57	VERDE MS-442 AFC CODE-F58	REFLECTION MS-438 AFC CODE-F59	VERONA MS-444 AFC CODE-F60
					
BRAMBLE MS-445 AFC CODE-F61	ARNO MS-447 AFC CODE-F62	GREYSTONE MS-448 AFC CODE-F63	MINK MS-449 AFC CODE-F64	ACID MS-450 AFC CODE-F65	GRANADA MS-425 AFC CODE-F66
					
PEACH MS-432 AFC CODE-F67	DUOMO MS-443 AFC CODE-F68	DARK FOREST MS-437 AFC CODE-F69	OLIVE MS-439 AFC CODE-F70	CARAMEL MS-435 AFC CODE-F71	PEACH CREAM MS-431 AFC CODE-F72